

Data Sheet | Item Number: 773-106

PUSH WIRE® connector for junction boxes; for solid and stranded conductors; max. 2.5 mm²; 6-conductor; transparent housing; violet cover; Surrounding air temperature: max 60°C; 2,50 mm²; multicoloured

<https://www.wago.com/773-106>



Color: multi-colored

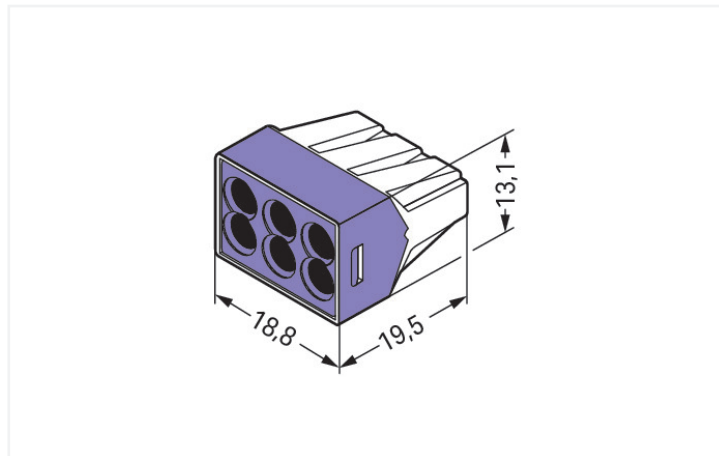

Dimensions in mm

Notes

Sicherheitshandhabungshinweis

NOTICE: Observe installation and safety instructions!

- **Only to be used by electricians!**
- Do not work under voltage/load!
- Use only for proper use!
- Observe national regulations/standards/guidelines!
- Observe technical specifications for the products!
- Observe the number of permissible potentials!
- Do not use damaged/dirty components!
- Observe conductor types, cross-sections and strip lengths!
- Insert conductor until it hits the product's backstop!
- Use original accessories!

Safety information

To be sold only with installation instructions!

in grounded power lines

Electrical data

Ratings per	IEC/EN 60664-1		
Overvoltage category	III	III	II
Pollution degree	3	2	2
Nominal voltage	-	-	400 V
Rated surge voltage	-	-	4 kV
Rated current	-	-	24 A

Connection data

Connection points	6
Total number of potentials	1

Connection 1

Connection technology	PUSH WIRE®
Actuation type	Push-in
Connectable conductor materials	Copper Aluminum



Connection 1

Connectable conductor materials (note) **Terminating Aluminum Conductors (Not for use in North America)**
 WAGO spring clamp terminal blocks are suitable for solid aluminum conductors up to 4 mm²/12 AWG if WAGO "Alu-Plus" Contact Paste [249-130](#) is used for termination.

"Alu-Plus" Contact Paste Advantages:

- Automatically destroys the oxide film during clamping.
- Prevents fresh oxidation at the clamping point.
- Prevents electrolytic corrosion between aluminum and copper conductors (in the same terminal block).
- Provides long-term protection against corrosion.

For spring clamp connections with PUSH WIRE® connection technology, **WAGO recommends that the aluminum conductor first be cleaned** and then immediately inserted into the clamping unit filled with "Alu-Plus" contact paste.

It is also possible to apply WAGO "Alu-Plus" **additionally** on the whole surface of the aluminum conductor before termination.

Please note that the nominal currents must be adapted to the reduced conductivity of the aluminum conductors::
 2.5 mm² = 16 A
 4 mm² = 22 A

Solid conductor	0.75 ... 2.5 mm ² / 18 ... 12 AWG
Stranded conductor	1.5 ... 2.5 mm ² / 16 ... 12 AWG
Note (conductor cross-section)	When using conductors of the same diameter, 0.75 mm ² /18 AWG cross-section is also possible.
Strip length	12 mm / 0.47 inches
Wiring direction	Side-entry wiring

Physical data

Width	18.8 mm / 0.74 inches
Height	13.1 mm / 0.516 inches
Depth	19.5 mm / 0.768 inches

Material data

Note (material data)	Information on material specifications can be found here
Color	multi-colored
Cover color	violet
Flammability class per UL94	V2
Fire load	0.076 MJ
Weight	3.5 g

Environmental requirements

Ambient temperature (operation)	+60 °C
Continuous operating temperature	105 °C

Commercial data

Product Group	7 (Push Wire Conn.)
eCl@ss 10.0	27-14-11-04
eCl@ss 9.0	27-14-11-04
ETIM 8.0	EC000446
ETIM 7.0	EC000446
PU (SPU)	500 (50) pcs
Packaging type	Box
Country of origin	CN
GTIN	4044918397681
Customs tariff number	85369010000

Environmental Product Compliance

RoHS Compliance Status	Compliant, No Exemption
------------------------	-------------------------

Approvals / Certificates

General approvals



Approval	Standard	Certificate Name
CCA UL International Demko A/ S	EN 60998	CCA-DK No. 2520
CSA DEKRA Certification B.V.	C22.2	15411 (LR46759)
KEMA/KEUR DEKRA Certification B.V.	EN 60998	71-101747
ÖVE Österreichischer Verband für Elektrotechnik	EN 60998	1193-031-09
UL UL International Germany GmbH	UL 486C	E69654
UL UL International Germany GmbH	EN 60998	D-03479-A1

Declarations of conformity and manufacturer's declarations

Approval	Standard	Certificate Name
EU-Declaration of Confor- mity WAGO GmbH & Co. KG	-	-
UK-Declaration of Confor- mity WAGO GmbH & Co. KG	-	-

Approvals for marine applications



Approval	Standard	Certificate Name
ABS American Bureau of Ship- ping	-	18-HG1755093-PDA
BV Bureau Veritas S.A.	EN 60998	11914/D0 BV
DNV GL Det Norske Veritas, Ger- manischer Lloyd	EN 60998	TAE000015T
LR Lloyds Register	EN 60998	LR22207029TA

Downloads

Environmental Product Compliance

Compliance Search

Environmental Product
Compliance 773-106



CAD/CAE-Data

CAE data

WSCAD Universe
773-106



1 Compatible Products

1.1 Optional Accessories

1.1.1 Mounting adapter

1.1.1.1 Mounting accessories



Item No.: 773-332

Mounting carrier; 773 Series - 2.5 mm² / 4 mm² / 6 mm²; for DIN-35 rail mounting / screw mounting; orange

1.1.2 Tool

1.1.2.1 "Alu-Plus" contact paste



Item No.: 249-130

Syringe; Contents: 20 ml Alu-Plus contact paste